

# SHANGHAI

SHANGHAI MONOCHROMATIC 24Vdc

ISTRUZIONI DI MONTAGGIO  
MOUNTING INSTRUCTIONS  
MONTAGEANWEISUNGEN  
INSTRUCTIONS DE MONTAGE  
INSTRUCCIONES DE MONTAJE

安装说明书

إرشادات التركيب

# Indicazioni Generali General Information

**ALDABRA**  
PROFESSIONAL INTERIOR LIGHTING



$t_a = 0 \div 40^\circ\text{C}$

$t_c = \text{max } 90^\circ\text{C}$

**IP40**

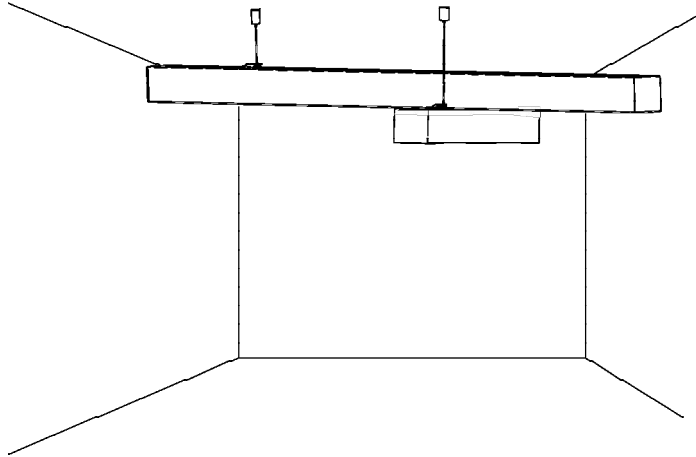

- I Posizioni di montaggio.
- GB Mounting positions.
- D Installationsarten.
- F Positions de montage.
- E Posiciones de montaje.
- CN 安裝位置.

تساعد المواقع KSA

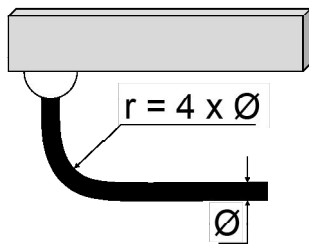

- I Raggio minimo di curvatura.
- GB Minimum bending radius.
- D Mindestbiegeradius.
- F Rayon de courbure minimum.
- E Radio de curvatura mínimo.
- CN 最小弯曲半径.

الحد الأدنى نصف قطرها الانحناء . KSA



- I Conservare le istruzioni.
- GB Store the instructions.
- D Behalten Sie die Montageanleitungen.
- F Conservez les instructions.
- E Conserve las instrucciones.
- CN 请保留此说明书

الإبقاء على تعليمات . KSA

- I Il modulo LED contenuto in questo apparecchio di illuminazione può essere sostituito esclusivamente dal costruttore.
- GB The LED module contained in this luminaire shall only be replaced by the manufacturer.
- D Das LED-Modul in dieser Leuchte enthalten darf nur vom Hersteller ersetzt werden.
- F La source lumineuse contenue dans ce appareil peut être échangé seulement par le constructeur.
- E El módulo LED contenida en esta luminaria sólo se sustituye por el fabricante.
- CN 該燈具中包含的LED模塊只能由製造商更換

يتم استبدال وحدة الصمام الواردة في هذا الإنارة فقط من قبل الشركة المصنعة KSA

# Indicazioni Generali General Information

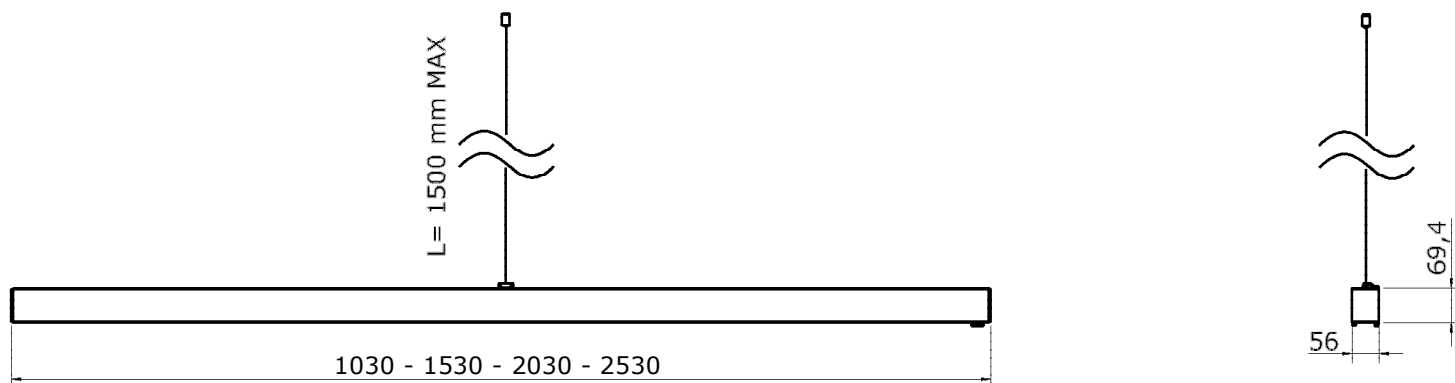

- I Pulire periodicamente gli apparecchi. Usare solo acqua e sapone.  
GB Periodically clean the fixtures. Use only water and soap.  
D Reinigen Sie die Leuchten regelmäßig. Verwenden Sie nur Wasser und Seife.  
F Nettoyer régulièrement l'équipement. Utilisez uniquement du savon et de l'eau.  
E Limpie periódicamente el equipo. Utilice sólo agua y jabón.  
CN 定期清洗设备。只能使用清水和肥皂。

المعدات النظيفة بشكل دوري. استخدام الماء والصابون فقط

KSA

- I L'installazione deve essere eseguita da personale qualificato.  
Togliere tensione prima di eseguire i collegamenti elettrici.  
Il rispetto di queste istruzioni è indispensabile per il corretto funzionamento del prodotto e dell'impianto
- GB The installation must be performed by qualified personnel.  
Remove power before making electrical connections.  
Following these instructions is essential for the proper functioning of the product and the plant.
- D Die Installation muss von qualifiziertem Fachpersonal durchgeführt werden.  
Schalten Sie die Spannung ab, bevor Sie die elektrische Verbindungen realisieren.  
Die Einhaltung dieser Anleitungen ist von wesentlicher Bedeutung für das ordnungsgemäße Funktionieren des Produkts und der elektrischen Anlage.
- F L'installation doit être effectuée par un personnel qualifié.  
Couper l'alimentation avant d'effectuer les connexions électriques.  
Le respect de ces instructions est essentiel pour le bon fonctionnement du produit et de la plante.
- E La instalación debe ser realizada por personal calificado.  
Desconecte la alimentación antes de realizar las conexiones eléctricas.  
El cumplimiento de estas instrucciones es imprescindible para el buen funcionamiento del producto y del sistema.
- CN 安装必须由专业人员来完成。  
进行电气连接前，确保先断开电源。  
遵循这些指令对于产品和场地的正常运行是必不可少的

يجب إجراء التثبيت من قبل موظفين مؤهلين .  
إزالة الكهربائي قبل إجراء التوصيلات الكهربائية .  
الامتثال لأحكام هذه التعليمات ضروري لحسن سير العمل المنتج والمصنع .

KSA

# Installazione Installation

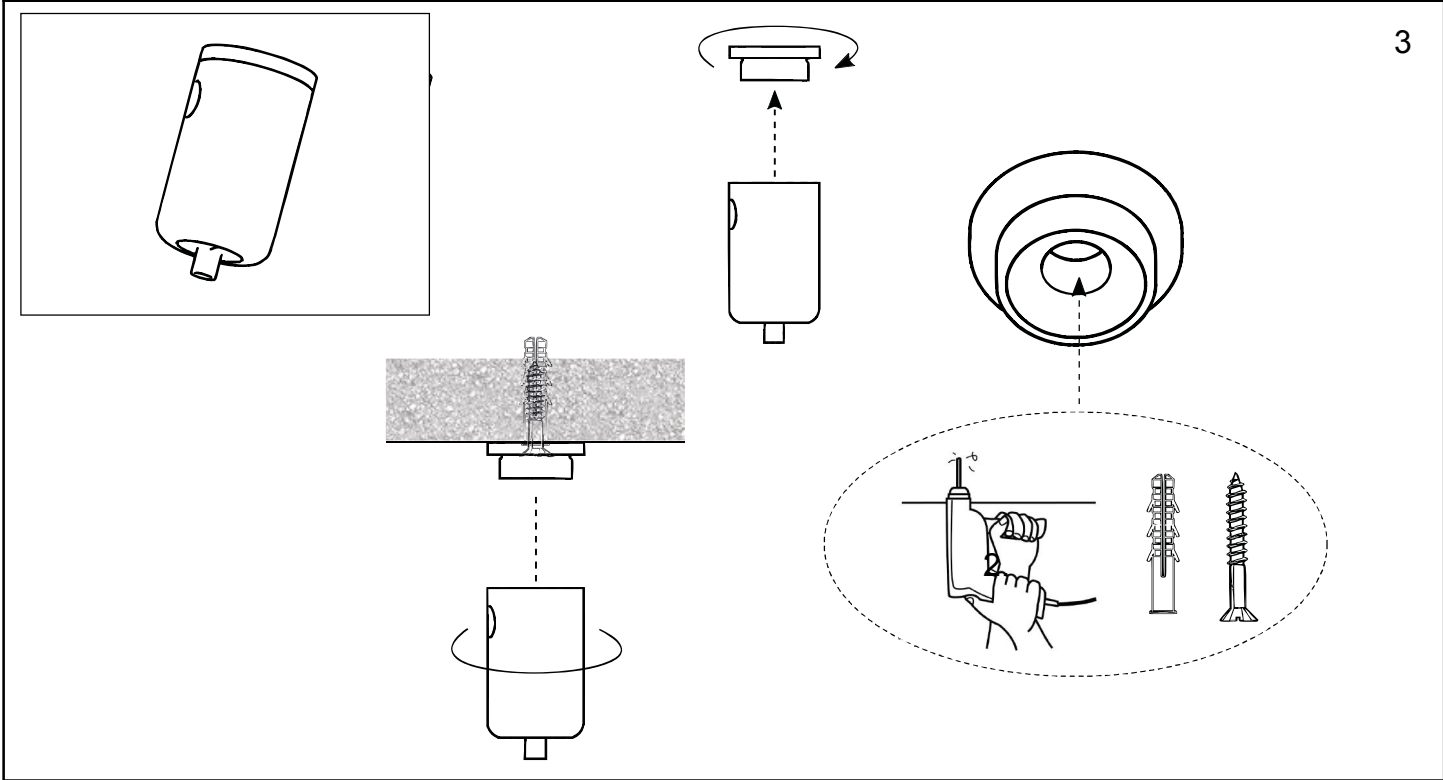
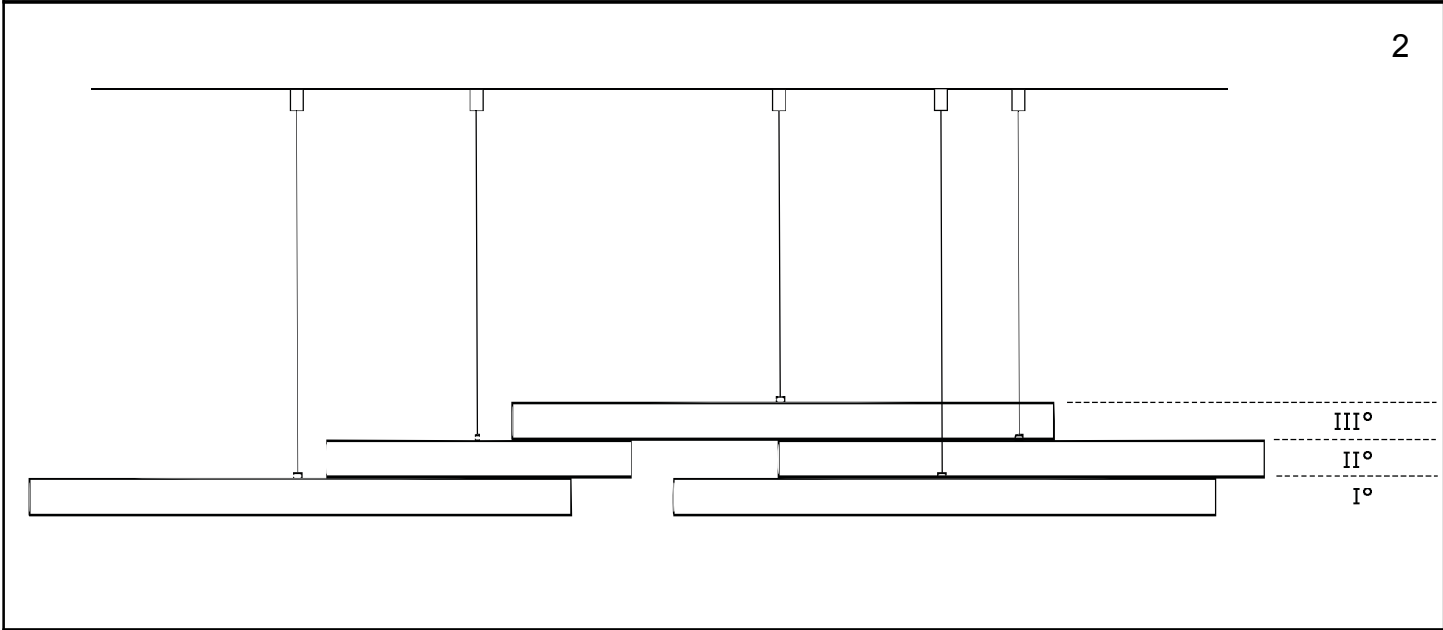
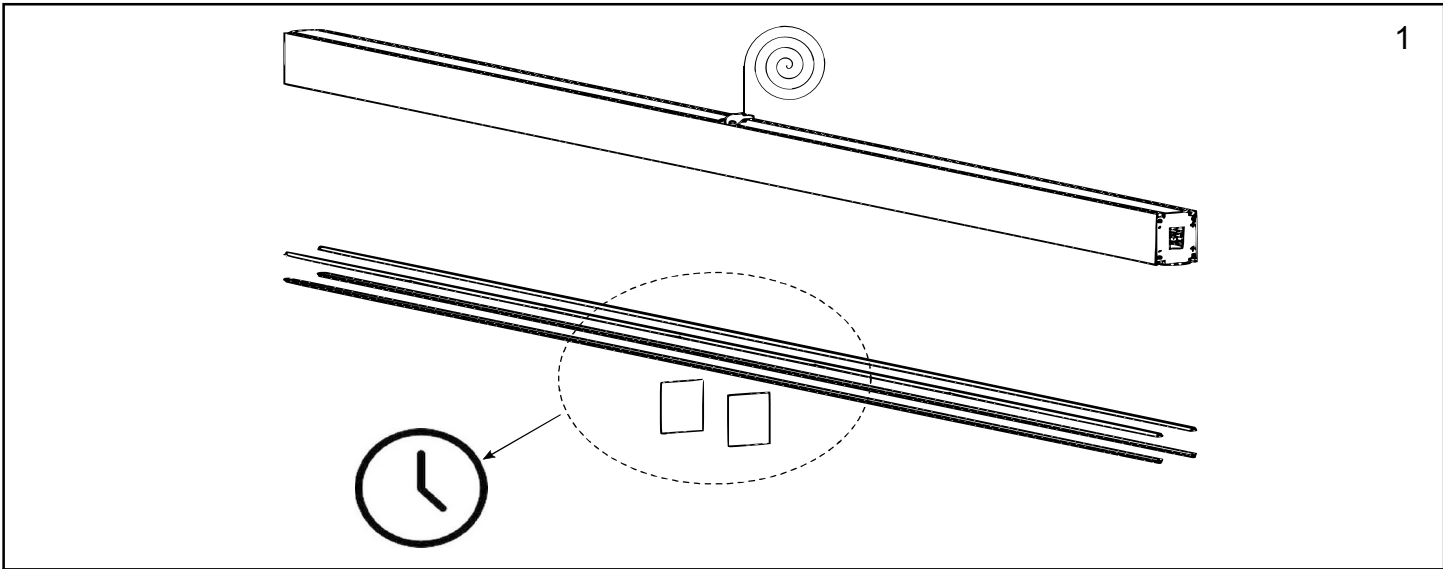

# Installazione Installation

